

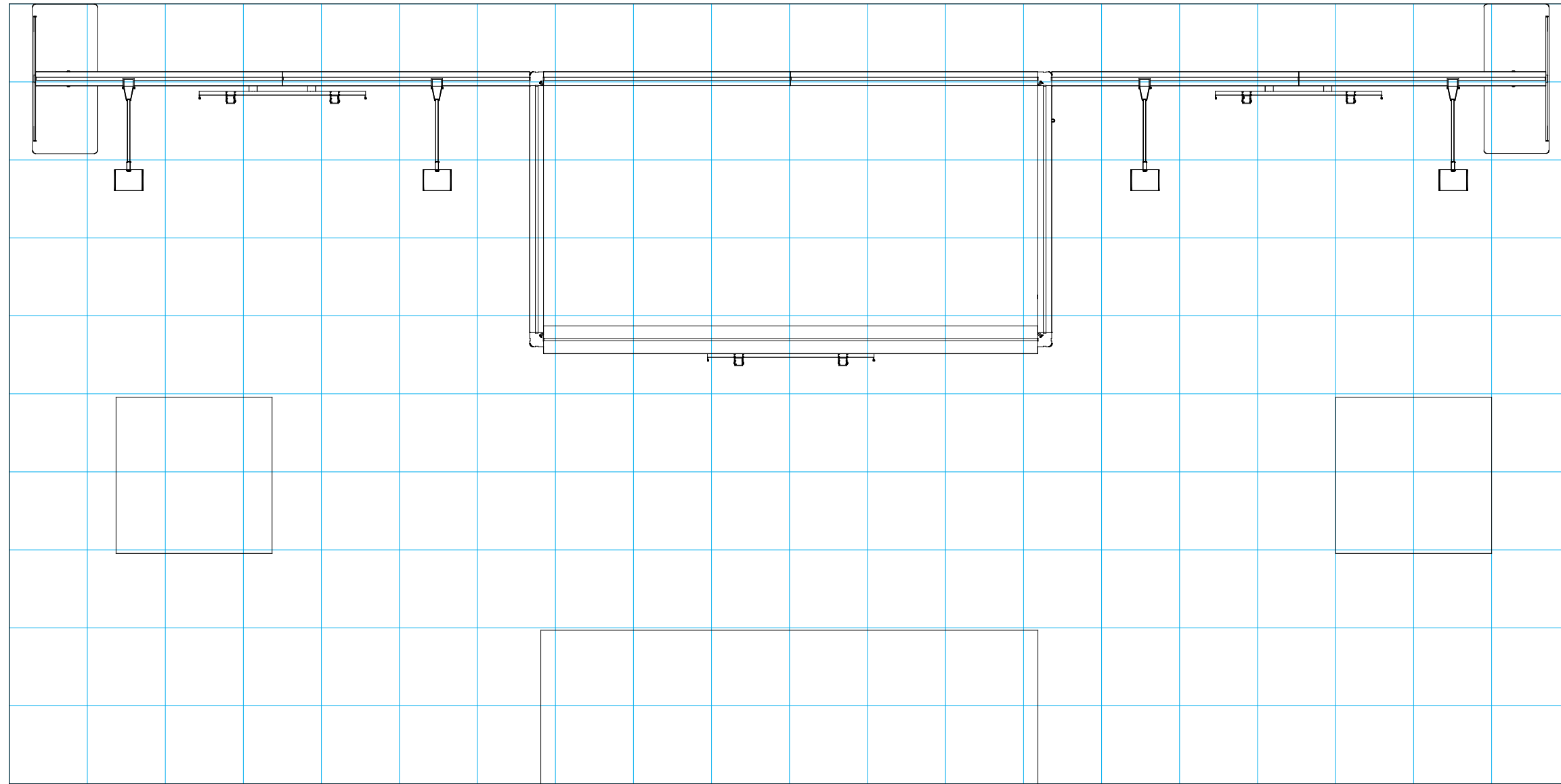

SETUP INSTRUCTIONS



 = 1 sq foot

General Setup Instructions

- Read entire setup instruction manual prior to unpacking parts and pieces.
- The setup instructions are created specifically for this configuration.
- Setup instructions are laid out sequentially in steps, including exploded views with detailed explanation for assembly.

Cleaning & Packing

- For Cleaning Metal, Plex, & Laminate Parts: Use a **MILD NON-ABRASIVE** cleanser and soft cloth/paper towel to clean all surfaces.
- Keep exhibit components away from heat and prolonged sun exposure. **Heat and UV exposure will warp and fade components.**
- Retain all provided Packing Materials. All provided packing materials are for ease of repacking & component protection.

Disassembly

- For loss prevention, tighten all set screws and locks during disassembly.

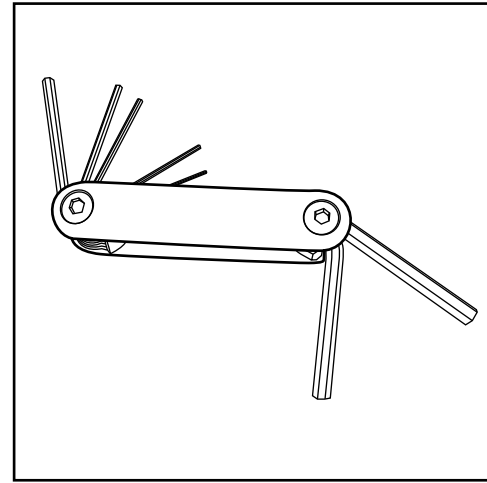

Hex Tool - Essential for Assembly

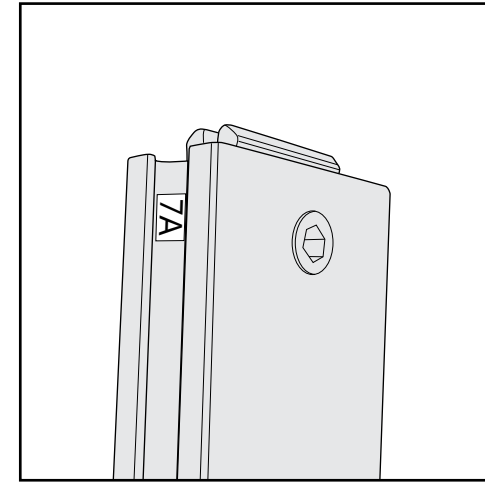

Part Identification - Numbering

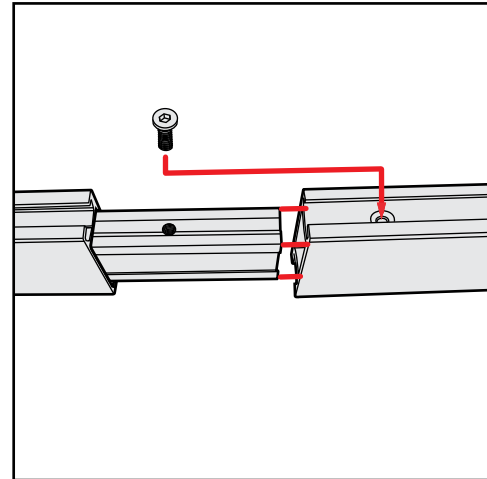

Spline Connection

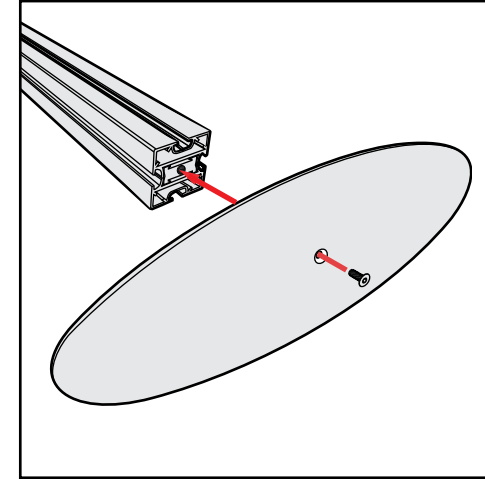

Base Plate & Extrusion Connection

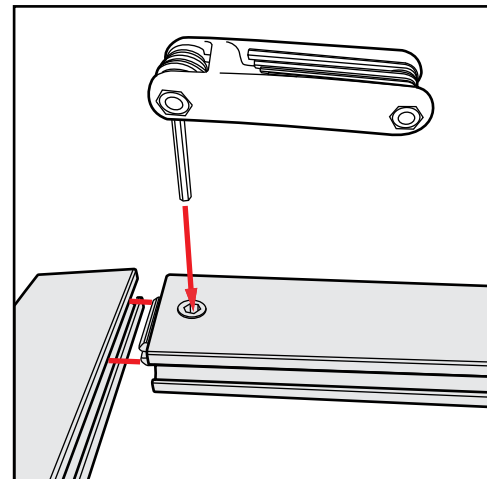

Extrusion & Lock Connection

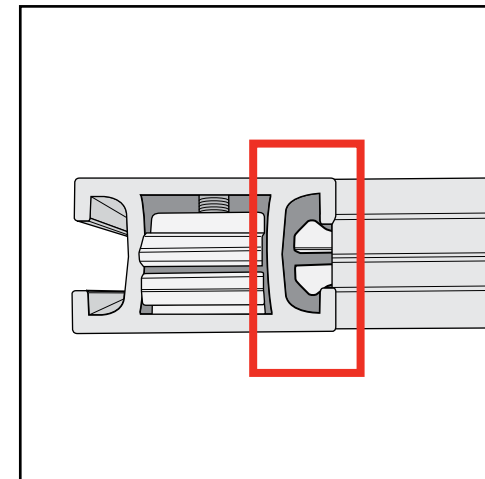

Engaged Lock



WARNING

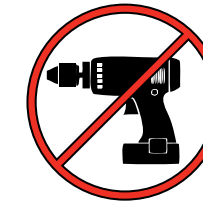

DO NOT USE POWER TOOLS

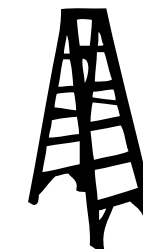

LADDERS OR LIFTS
MAY BE REQUIRED



ALL CONNECTIONS MUST
BE TIGHTLY SECURED

Side-by-Side Assembly

- 1) Frames: Place frames side-by-side with one higher than the other, then slide panel down to lock panels securely together.
- 2) Corner Connectors: Repeat Step 1 for installing corner connectors to frames.

Side-by-Side Disassembly

- 1) Pull pin lock outwards to disengage.
- 2) Pull frames upward and apart at the same time to detach.

Assembly

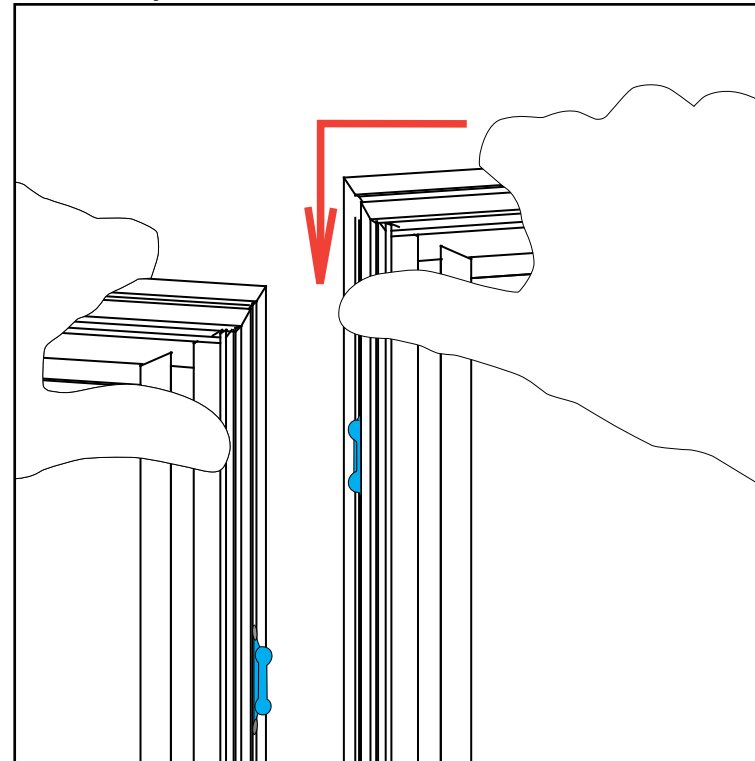

Assembly Cont'd

Push pin lock into hole of connecting frame.
Note: Block of pin lock will secure in groove.

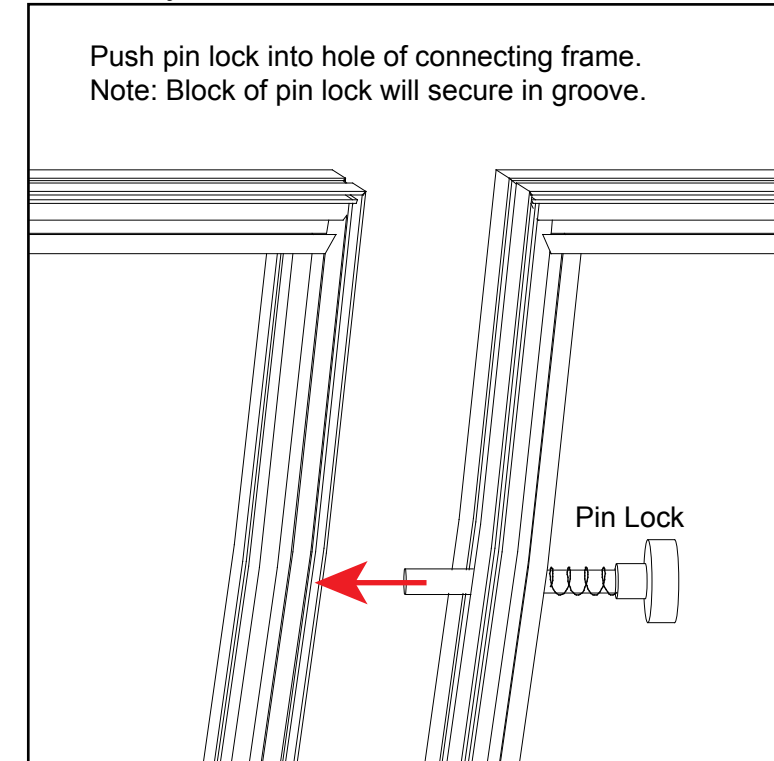

Corner Connector

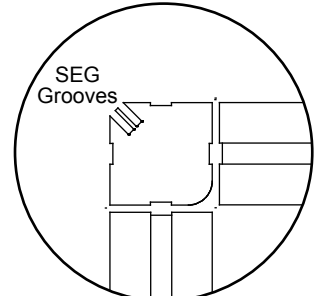

Top View
Note: Orientation of Corner Connector may change.

Stacking Assembly

- 1) Place one horizontal frame on top of the other, lining up the center grooves.
- 2) Turn stacking lock clockwise to tighten into place. Repeat for each lock.

Stacking Disassembly

- 1) Turn the stacking lock counter-clockwise to loosen.
- 2) The whole spring on the stacking lock should be in view to release each frame. The disengaged spring should release the stacking lock. If not, keep turning the stacking lock until it disengages.

Stacking

Push stacking lock into the slot of the upper frame, then spin the cap to tighten the lock.

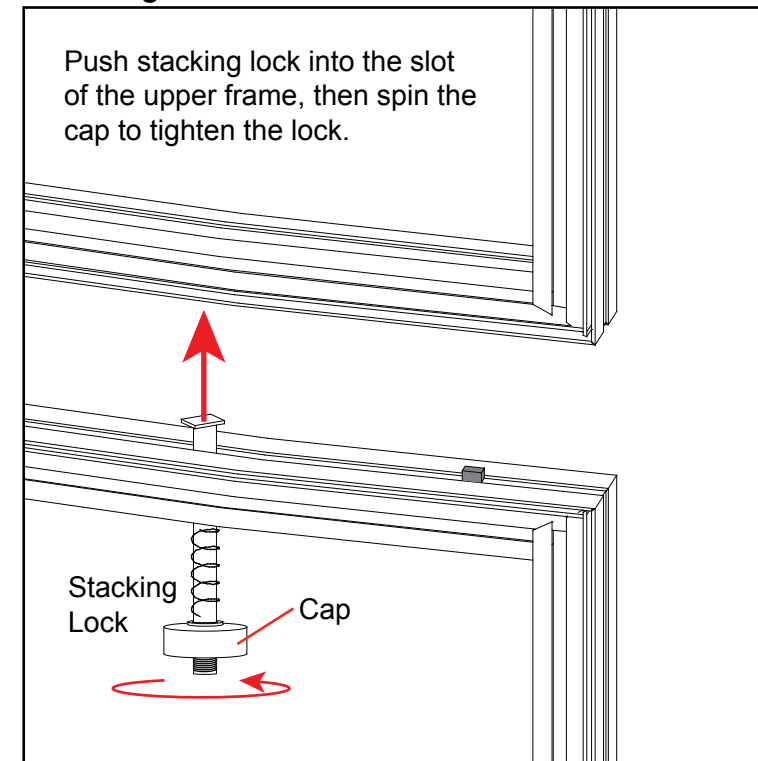

Unstacking

Disengage the stacking lock by spinning the cap counter clockwise and pulling down.

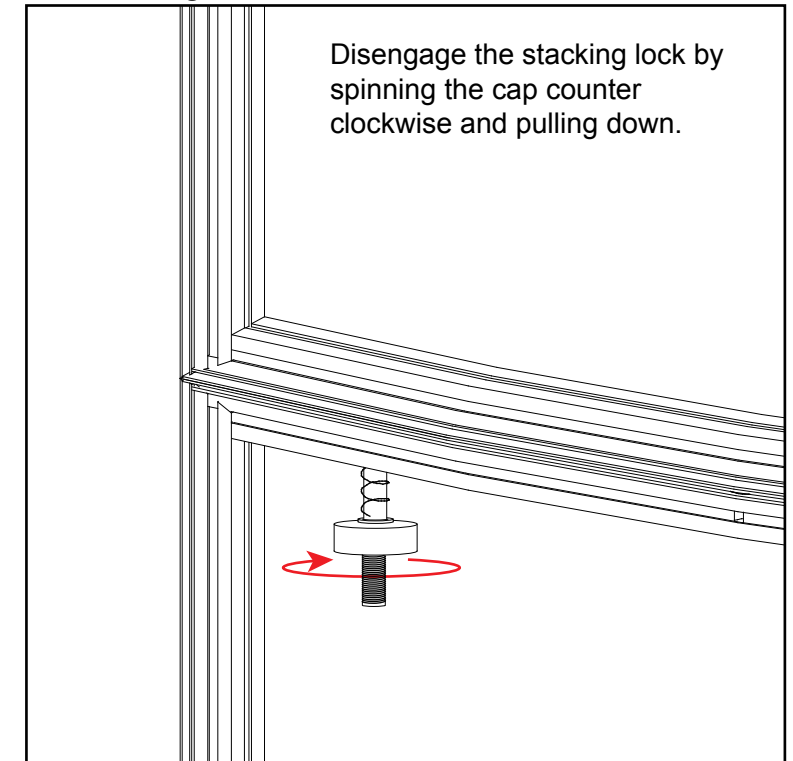

SEG Graphic Installation *in 3 Steps*

The Perfect Fit

STEP 1: Attach Corners

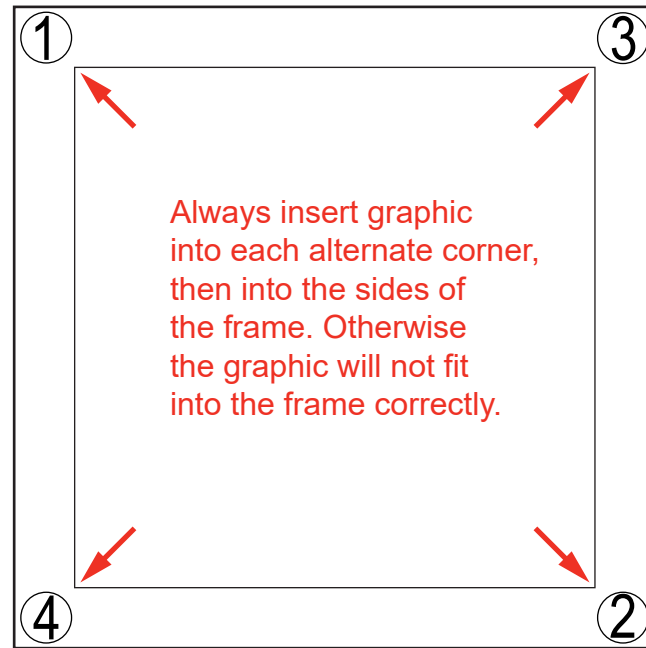

STEP 2: Attach Middle

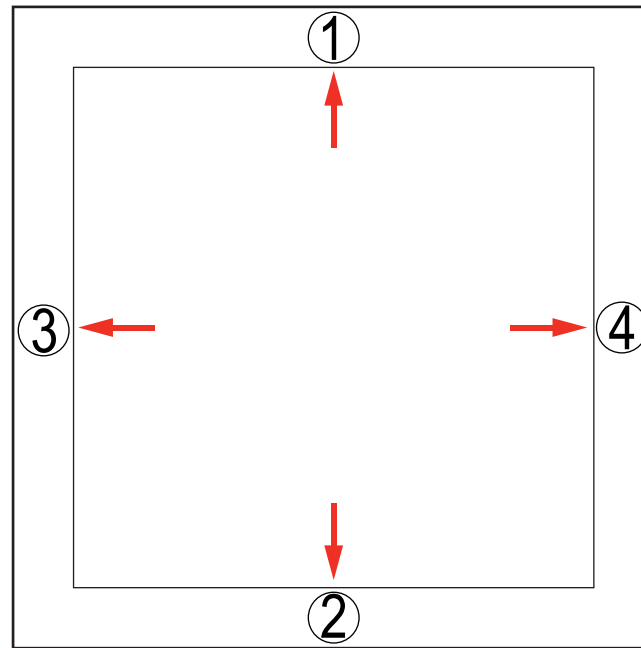

STEP 3: Attach Sides

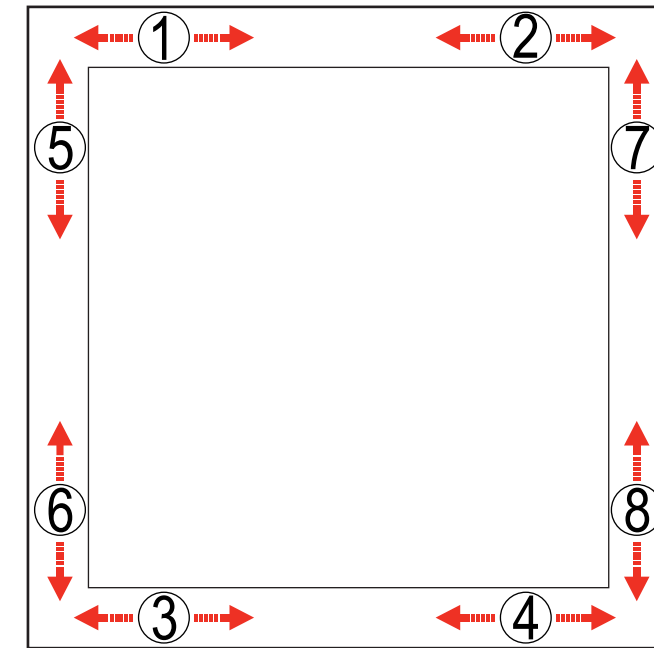

Insert narrow side of silicone welt into the channel at corner 1, with fabric to the outside.

Repeat for opposite corner 2, then corner 3, then corner 4.

Once corners are attached, press the middle of edge 1 into the channel. Then press middle of edge 2 into the channel on opposite side.

Repeat with edge 3 & 4.

Once the middle of sides are attached, fully press the silicone welt into the channel, between center and corner at location 1. Repeat the process between center and corner at location 2.

Do the same for welt on opposite side, at locations 3 & 4. Then repeat for locations 5 & 6 and 7 & 8.

Once the welt is fully inserted on all sides, smooth out edges as needed for a perfect fit.



To remove the graphic from the frame, locate the fabric **pull tab**. Gently pull on the tab to remove the graphic.

Install video:



CRATE PACKING

Item	Qty.	Description
1	1	38" w x 95" h Gravitee Panel w/ S44
2	1	38" w x 95" h Gravitee Panel w/ S44
3	1	95" h Gravitee Corner Post
4	1	38" w x 95" h Gravitee Panel
5	1	95" h Gravitee Corner Post
6	1	38" w x 95" h Gravitee Panel
7	1	38" w x 95" h Gravitee Panel
8	1	95" h Gravitee Corner Post
9	1	38" w x 95" h Gravitee Panel w/ Door
10	1	95" h Gravitee Corner Post
11	1	38" w x 95" h Gravitee Panel w/ S44
12	1	38" w x 95" h Gravitee Panel w/ S44
1	2	SF17 Boomerang Base Plate

Steps:

- 1) Attach Base Plates [1] to Gravitee panels [1] & [12].
See **Base Plate Attachment** detail.
- 2) Assemble Gravitee panels & posts [1] through [12] in numerical order as shown. Refer to the *Gravitee Assembly general information page*.

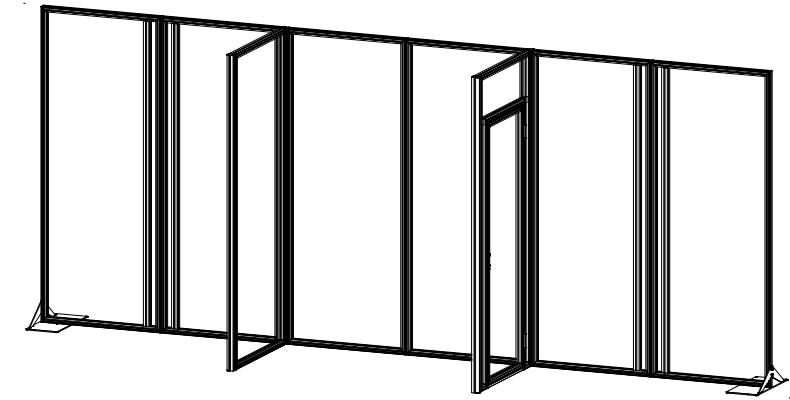

When assembled

Keep S44 verticals attached to Gravitee panels [1] [2] [11] and [12].

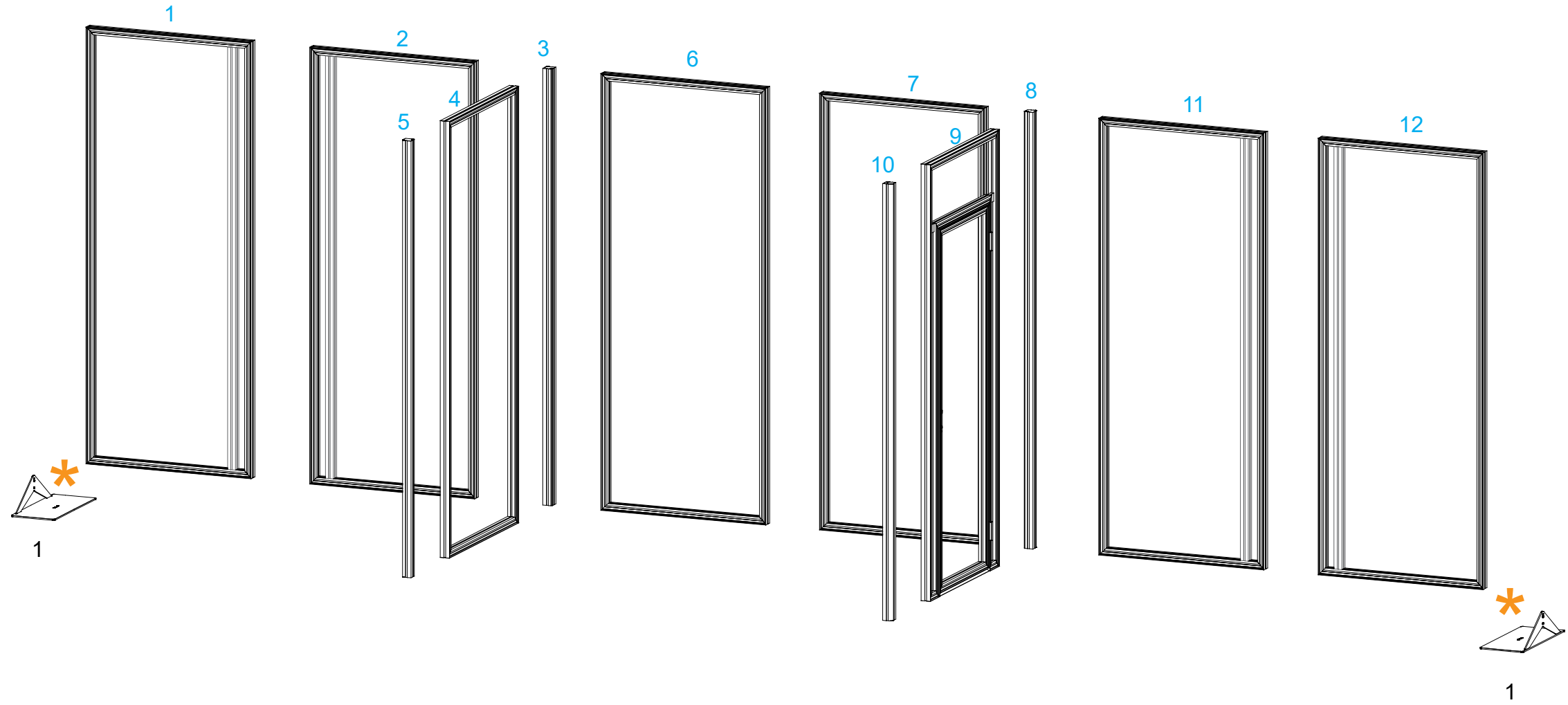
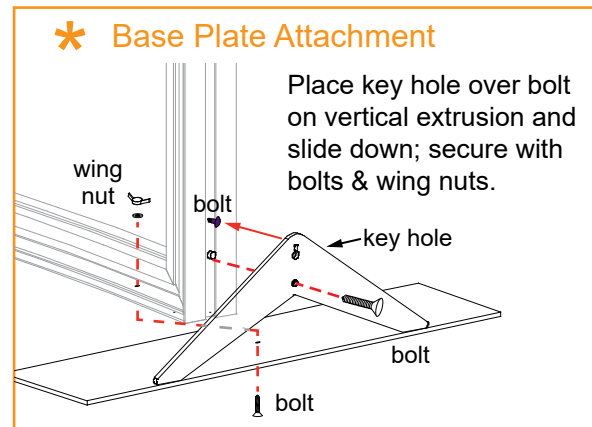

FRONT VIEW

Item	Qty.	Description
2	1	95"h CEI110 Vertical Extrusion
3	1	95"h CEI110 Vertical Extrusion
4	1	76"w CEI110 Horizontal Extrusion
5	1	76"w CEI110 Horizontal Extrusion
6	2	91.3534"h Z45 Vertical Extrusion

Steps:

- 1) Assemble verticals [2,3] between horizontals [4,5] using corner connectors.
Refer to the CEI110 Frame Assembly general information page.
- 2) Attach verticals [6] between horizontals [4,5].
- 3) Connect power cords to Supernova lights as shown.

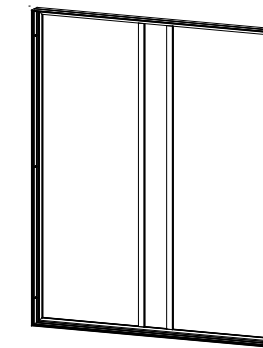

When assembled

Assemble frame flat on ground.

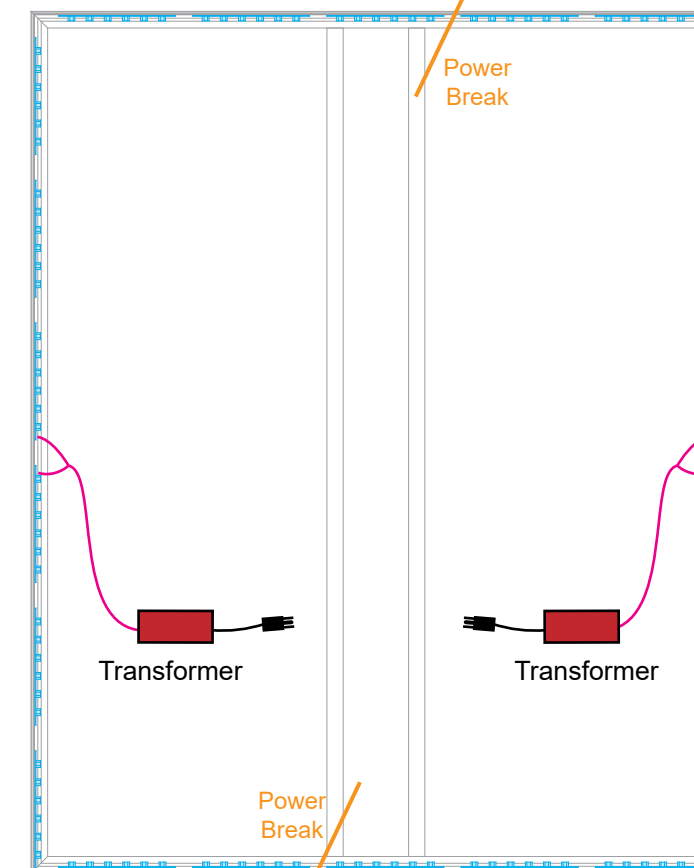
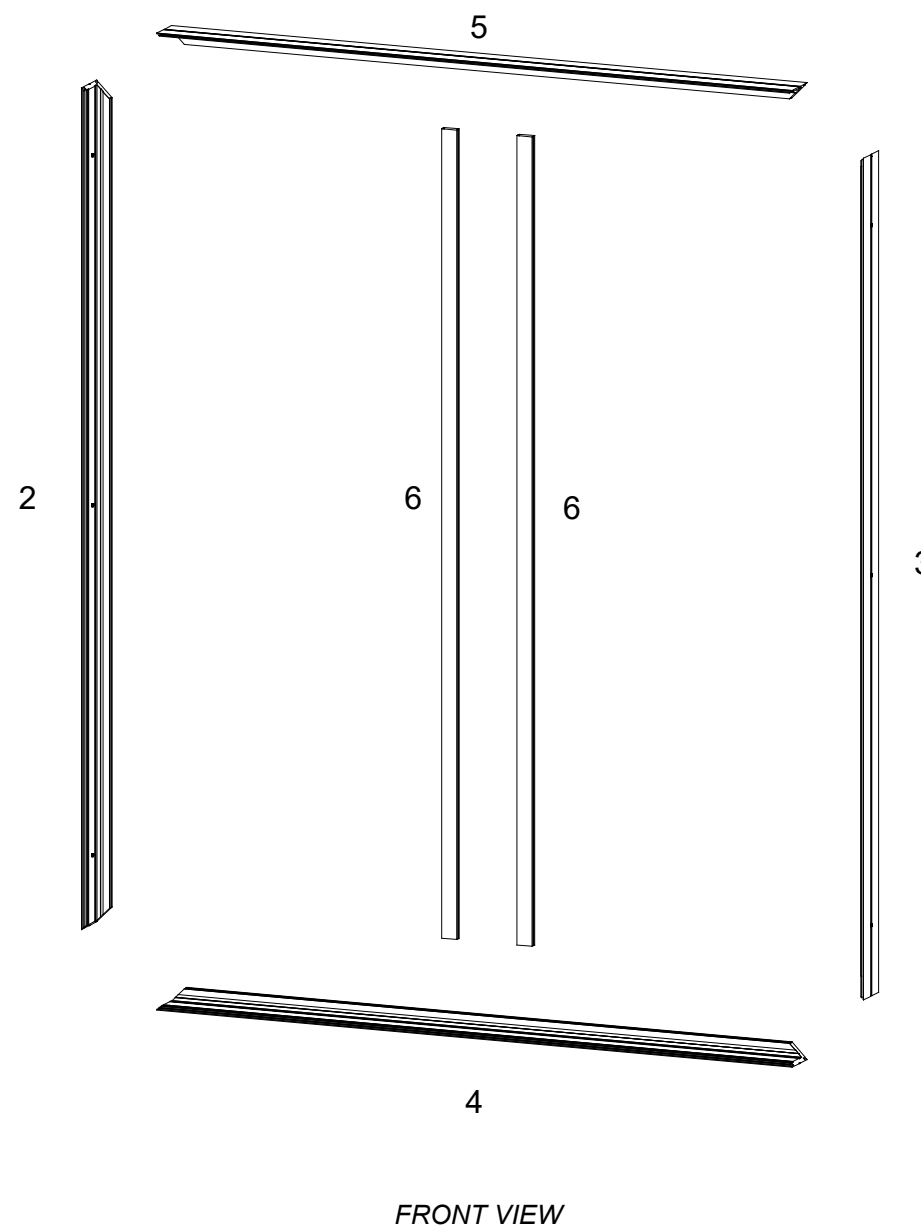

FRONT ELEVATION VIEW

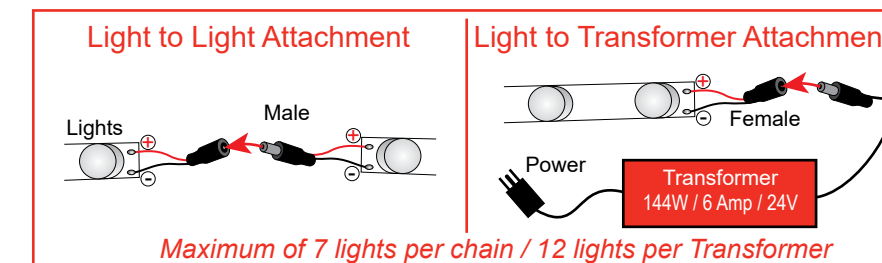

Steps:

- 1) Connect lightbox assembly to Gravitee posts [5] & [10].
See [Bolt to V4 Connection](#) detail.

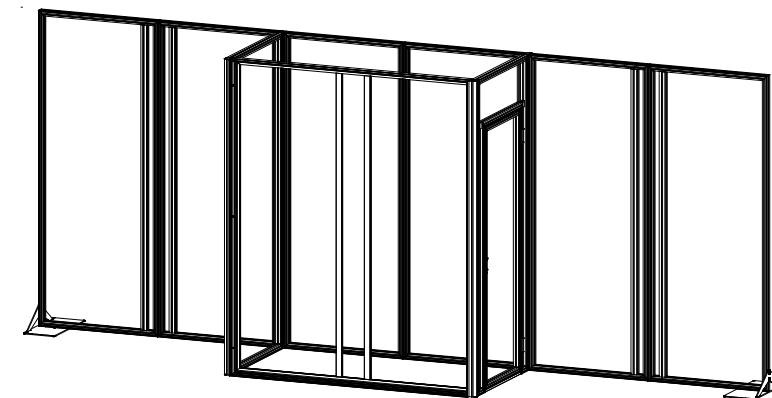

When assembled

*** Bolt to V4 Connection**

Slide V4 connector into groove of Gravitee post; secure with set screw.

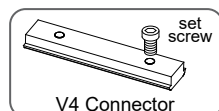

Attach lightbox extrusion to closet extrusion by securing bolt to hole of V4 connector.

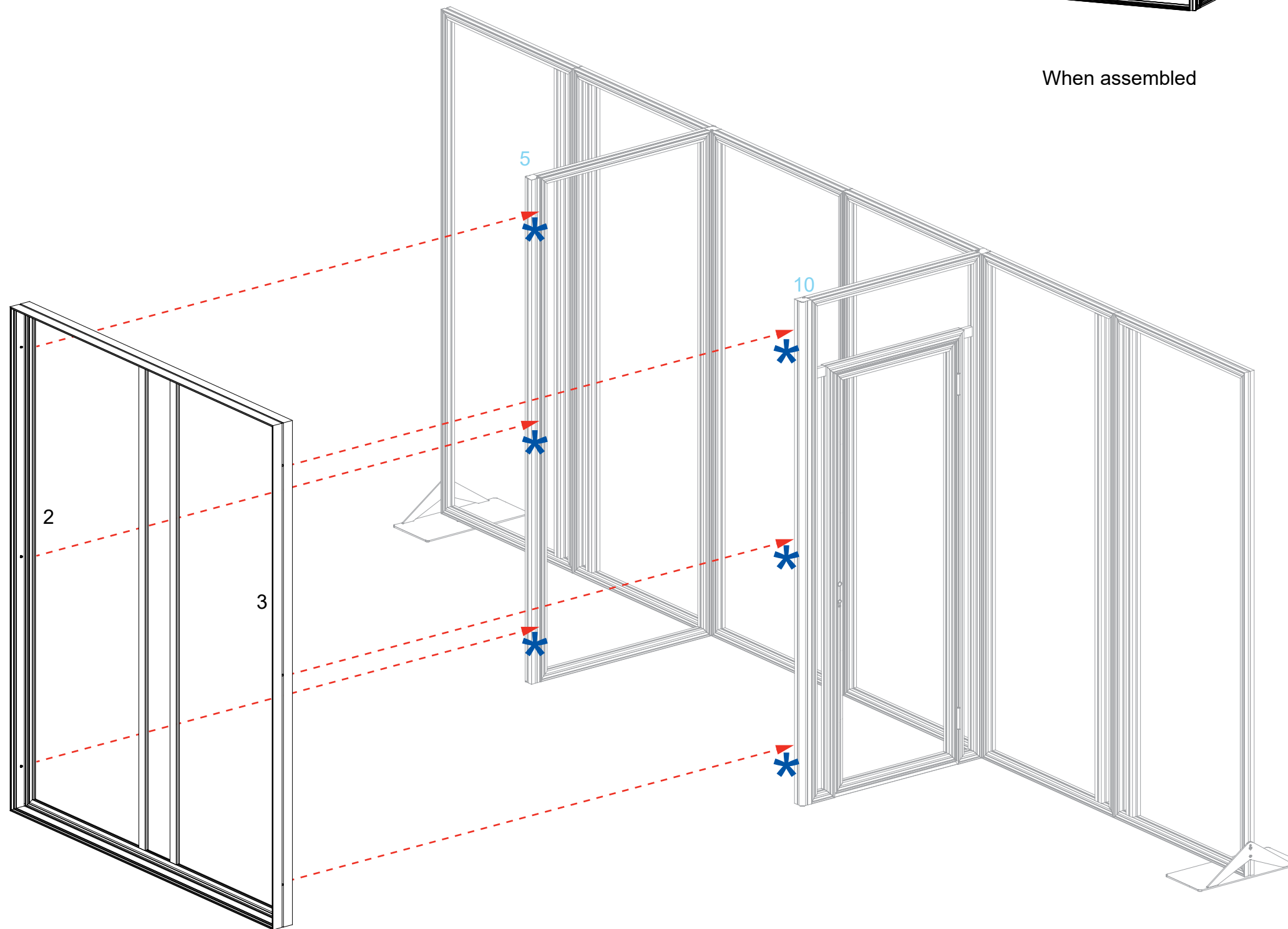
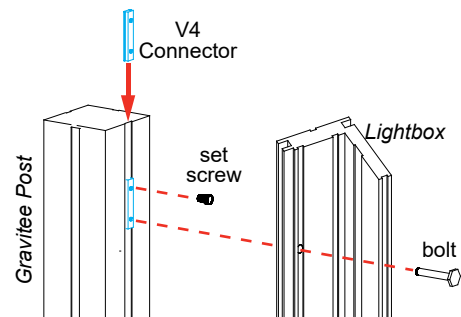

SEG Graphic Installation

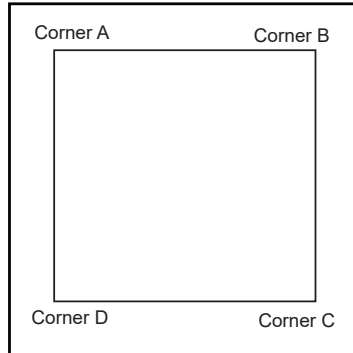

It is important to first insert graphic into each alternate corner, then to the sides of the frame. If this is not done, graphic will not fit into the frame correctly.

Step 1
Insert corner A. Turn edge of graphic so silicon welt is perpendicular to face of graphic. Insert narrow side of welt with fabric to outside into the channel. Repeat for other side of this corner.



Step 2
Repeat Step 1 for opposite corner C, then insert corner B, followed by corner D, to complete the installation of the corners.



Step 3
Once all corners are inserted, press one silicon edge into channel from corners and work toward the center. Make sure welt is fully inserted into channel. Continue until all sides are done. Smooth out edges of graphic.



Graphic Removal

To remove the graphic from the frame, locate the fabric pull tab. Gently pull up on the tab to remove the fabric.

Steps:
1) Apply SEG graphics & blockers to assembled backwall.

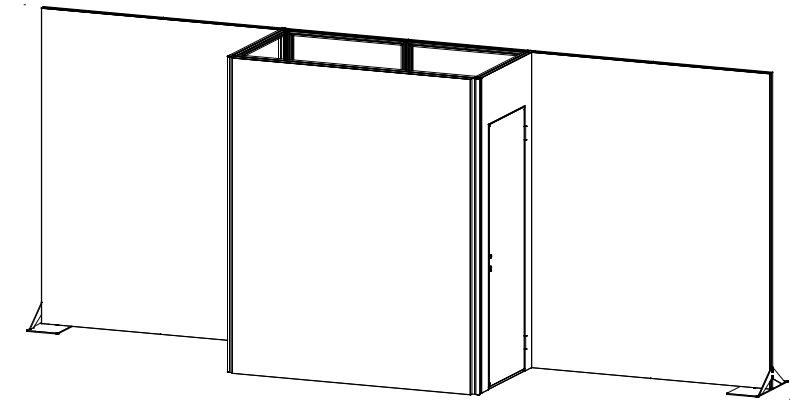

When assembled

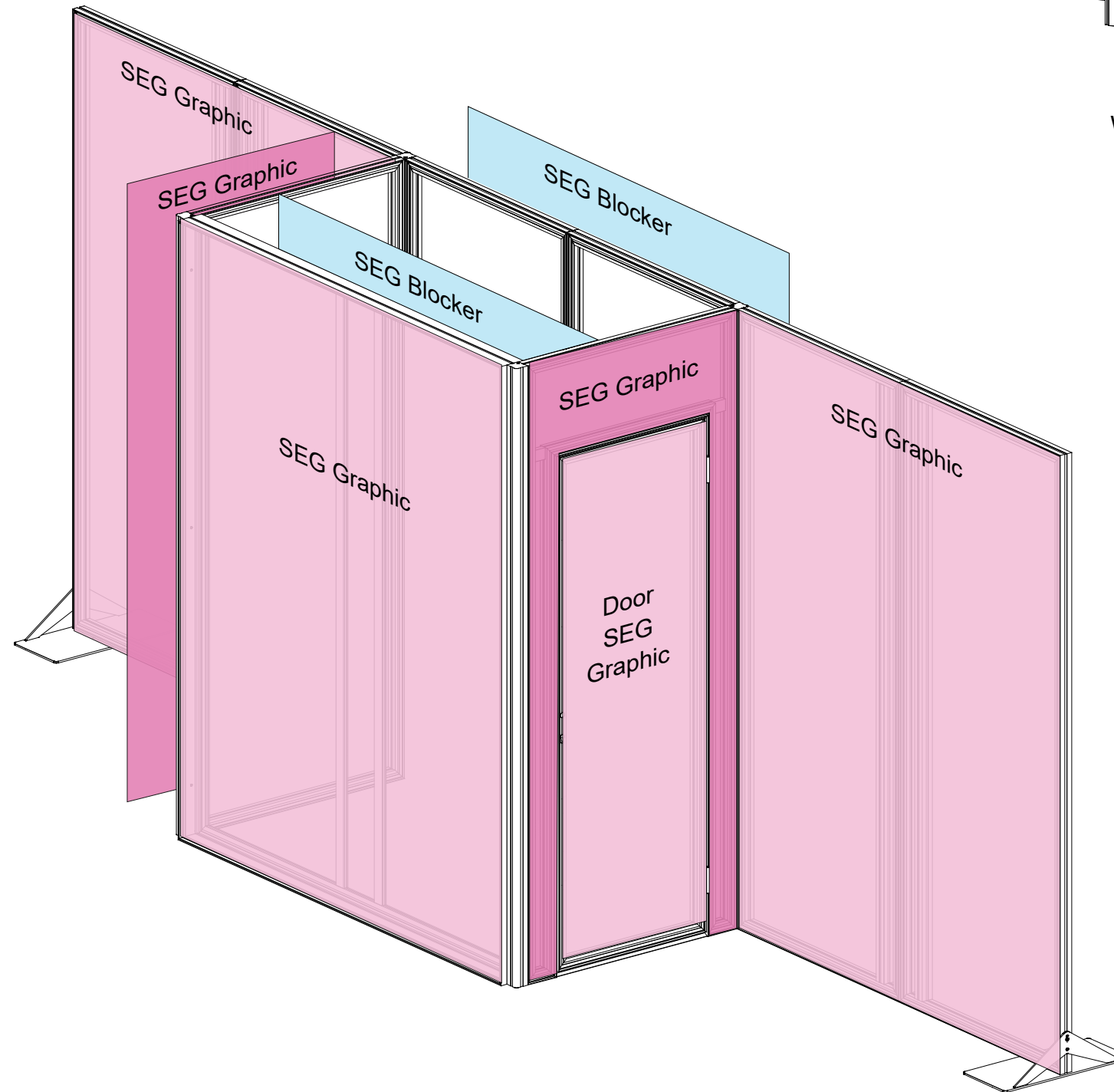

*** Monitor Mount Attachment**

Slide V4 connectors into vertical channel of extrusions. Tighten set screws to secure.

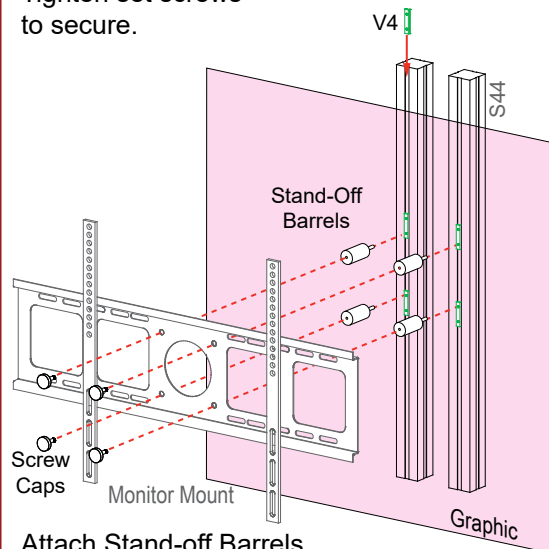
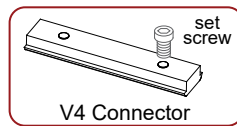

Attach Stand-off Barrels to V4 Connectors, then connect Monitor Mount to stand-offs using screw caps.

Note: Monitor mount installs over graphic.

*** Front Monitor Mount Attachment**

Attach Standoff Barrels to verticals using wing nuts. Then attach Monitor Mount to Standoff Barrels, using bolts.

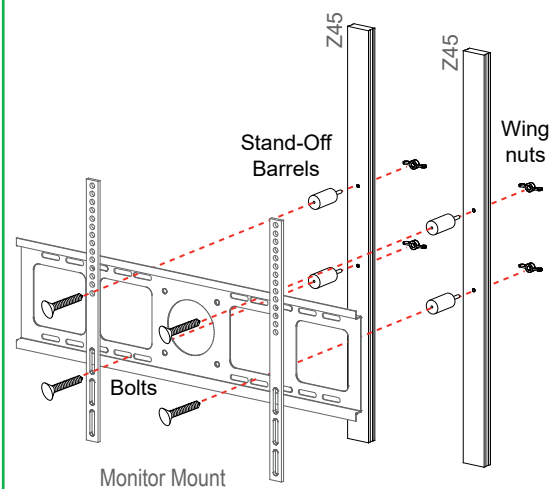

*** Light Attachment**

Attach lights to Horizontal where desired and tighten in place.

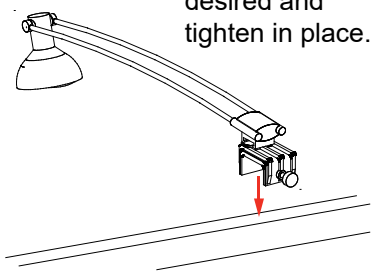

Steps:

- 1) Install Monitor Mount to S44 verticals in Gravitee panels [1/2] & [11/12]. See **Monitor Mount Attachment** detail.
- 2) Connect Monitor Mount to Z45 verticals in lightbox. See **Front Monitor Mount Attachment** detail.
- 3) Attach lights to backwall as shown. See **Light Attachment** detail.

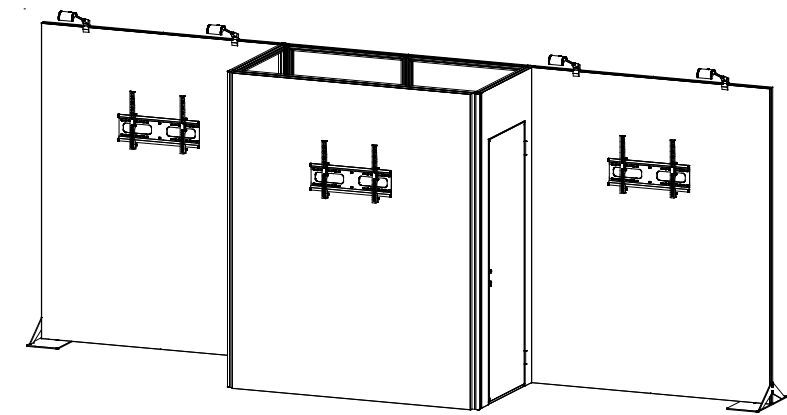

When assembled

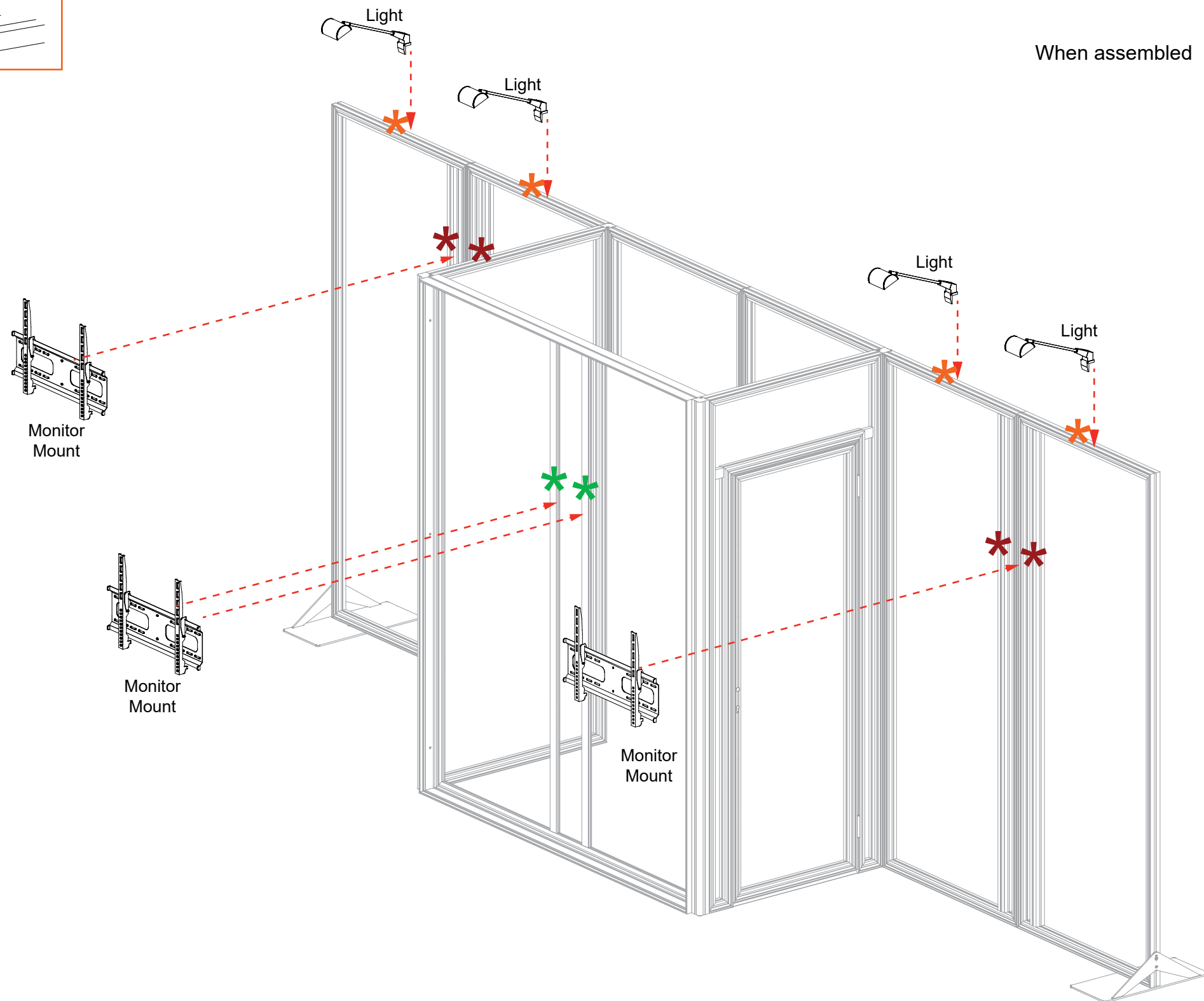

Controlling the RGB LED lights

Static Mode:

1. Use the Color Ring key to select a color.
2. Saturation is controlled with W/R/G/B keys.
3. White mode is available by long-pressing 'ON' key.
4. Colors (not white) are dimmable with the Brightness key.

Dynamic Mode:

Press "M" key to cycle through the following options:

1. White light fades in and out.
2. Several colors fade in and out.
3. R,G,B three colors fade in and out.
4. R,G,B three colors flash.
5. Six colors flash.
6. Random color flashes.
7. Red color fades in and flashes.
8. Green color fades in and flashes.
9. Blue color fades in and flashes.

To Pair a Remote with Multiple Units:

1. Power on the lights.
2. Press 'ON' key within 3 seconds.
3. Lights will blink when link is made.

To unpair: Long press 'ON' key within 3 seconds after switching on lights.

Remotes can be paired with one or more receivers. Different receivers can work synchronously even when started at different times (within 30 min).

Function of Keys

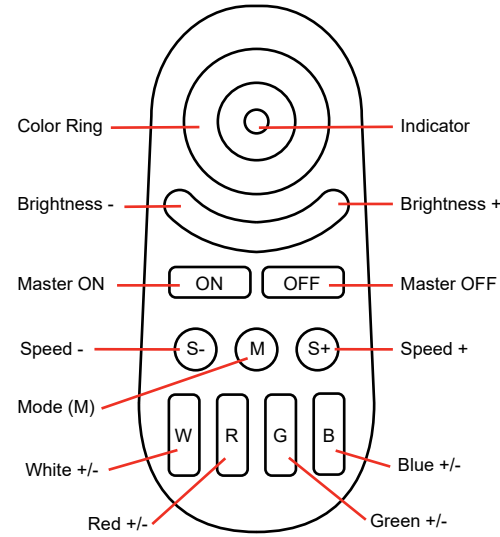

Specifications:

- | | |
|-------------------------------|-----------------------------|
| Receiver: | Remote Control: |
| 1. Working voltage: DC12V/24V | 1. Working voltage: 3V |
| 2. Output: Max. 6A/Channel | 2. Standby power: <20uA |
| Total output Max. 10A | 3. Transmitting power: 6dBm |
| 3. Max standby power: 0.5W | |

Steps:

- 1) Connect power cords to LED Lights in Counters, as shown.

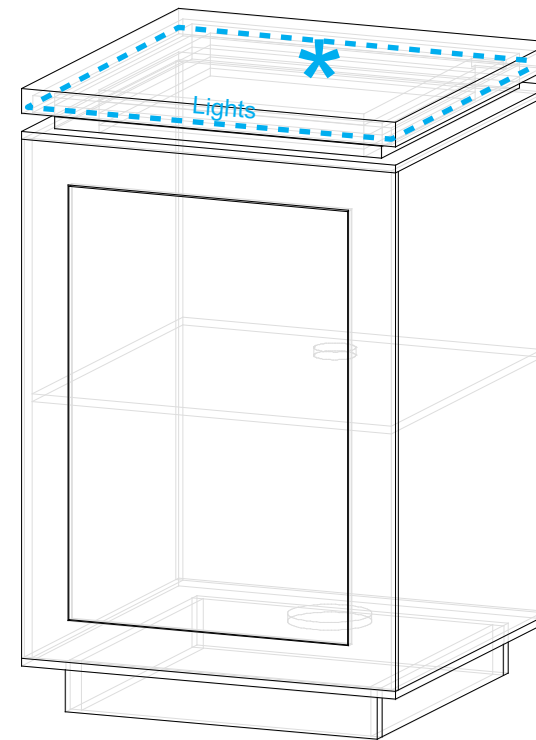

MOD-1593

Qty. 2

*** RGB LED Power Cord Attachment**

Connect transformer to RGB LED Controller. Then connect transformer to power source.

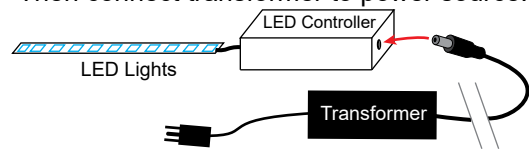

Item	Qty.	Description
1	1	38"h Q918 Vertical Extrusion
2	1	38"h Q918 Vertical Extrusion
3	1	38"h Q918 Vertical Extrusion
4	1	38"h Q918 Vertical Extrusion
5	1	38"h Q918 Vertical Extrusion
6	1	38"h Q918 Vertical Extrusion
7	1	32.155"w Z45 Horizontal Extrusion
8	1	32.155"w Z45 Horizontal Extrusion
9	1	32.155"w Z45 Horizontal Extrusion
10	1	32.155"w Z45 Horizontal Extrusion
11	1	15"w Z45 Horizontal Extrusion
12	1	15"w Z45 Horizontal Extrusion
13	1	15"w Z45 Horizontal Extrusion
14	1	15"w Z45 Horizontal Extrusion
15	1	15"w Z45 Horizontal Extrusion
16	1	15"w Z45 Horizontal Extrusion
17	1	32.155"w Z45 Horizontal Extrusion
18	1	32.155"w Z45 Horizontal Extrusion
19	1	32.155"w Z45 Horizontal Extrusion
20	1	32.155"w Z45 Horizontal Extrusion
--	2	Door
--	6	18"h Shelf Supports

Steps:

- 1) Assemble lower horizontals [7,9,11,13,15,17,19] between verticals [1,2,3,4,5,6].
- 2) Insert **infills** between verticals [1,2], [2,3], [3,4], [1,5].
- 3) Connect upper horizontals [8,10,12,14,16,18,20] between verticals [1,2,3,4,5,6].
- 4) Attach Doors between verticals [4,5], [5,6]. See [Door Attachment](#) detail.
- 5) Affix shelf supports to inside of counter assembly using Velcro; place shelf onto shelf supports.
- 6) Affix Sintra Panels to outside of assembly, using Velcro.
- 6) Attach Counter Top to top of assembly.

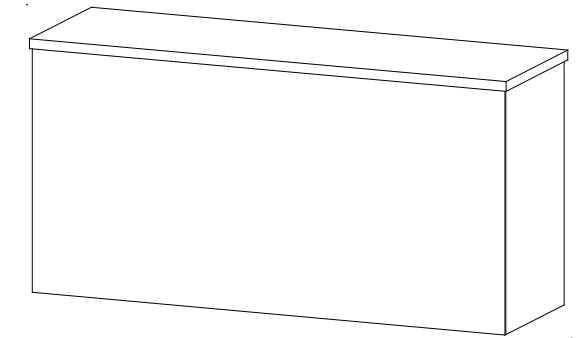

When assembled

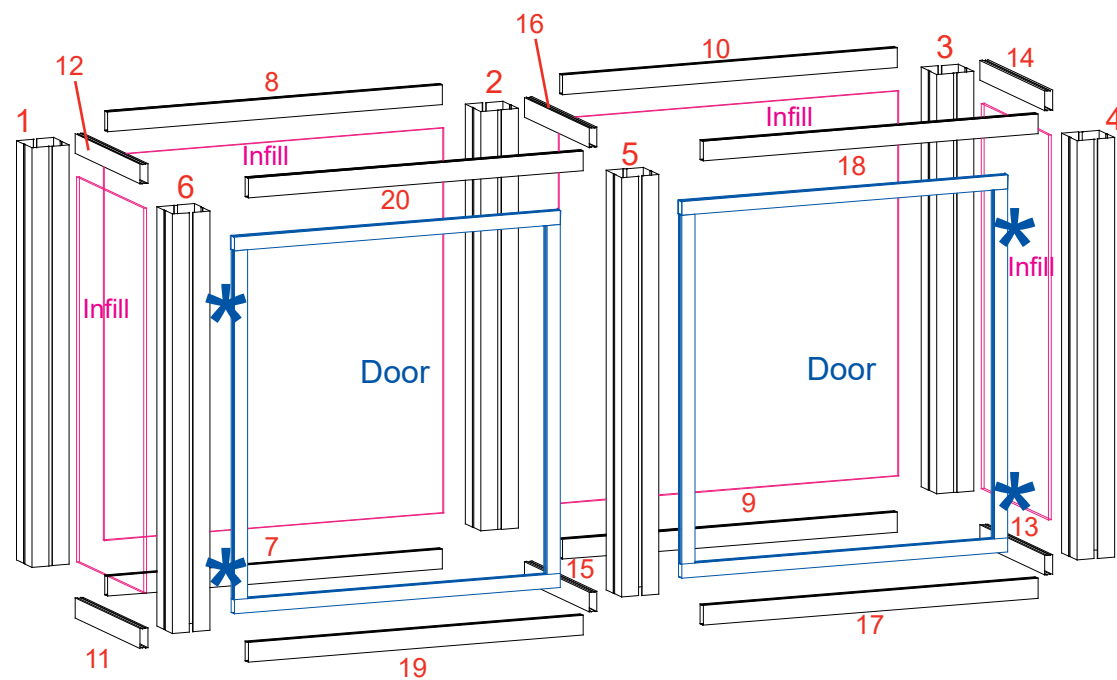
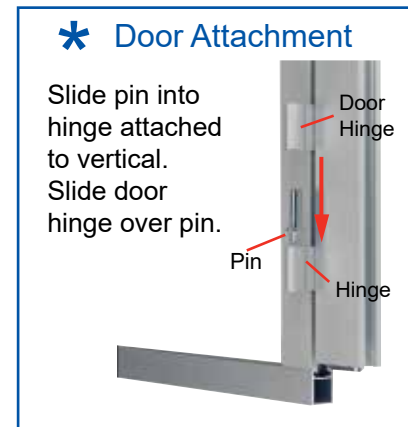

BACK VIEW

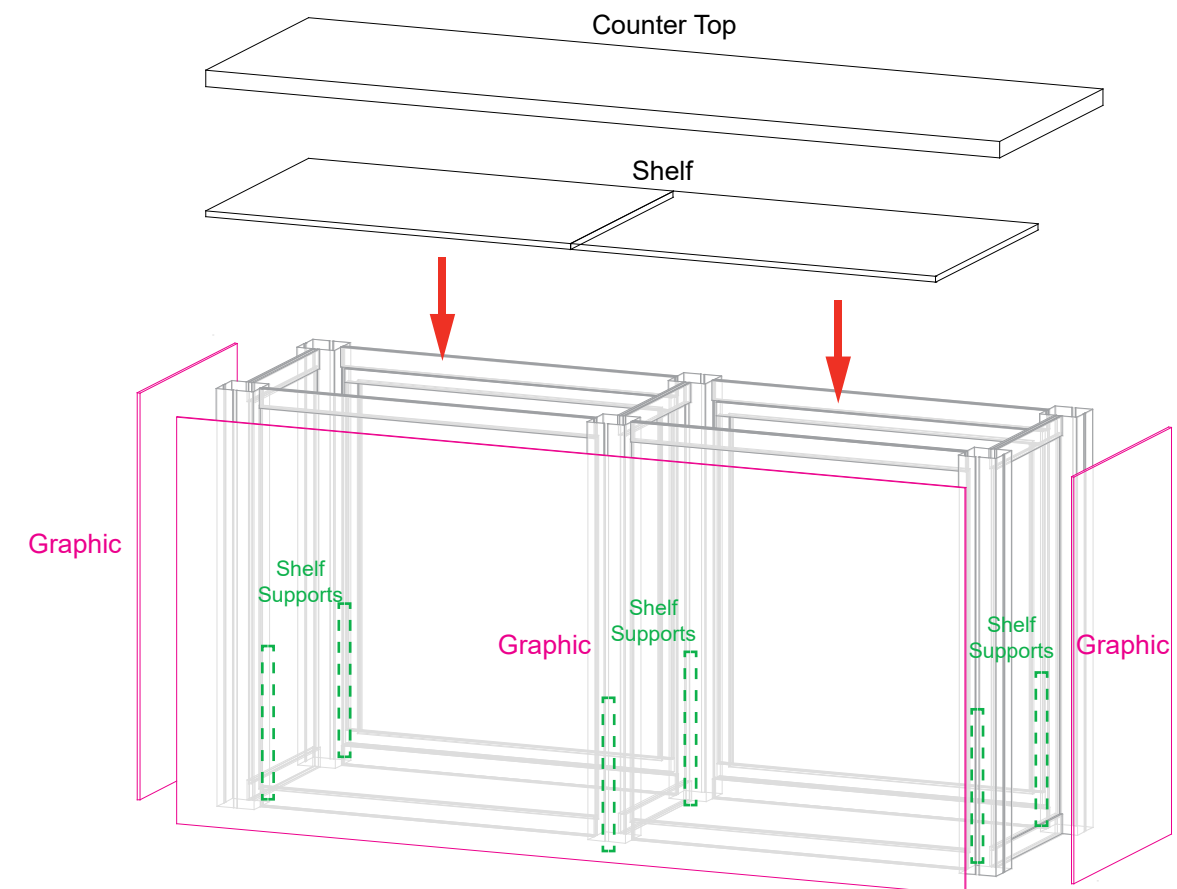

FRONT VIEW