

Assemble lower horizontal extrusions [5,6,7,8,9] between vertical extrusions [1,2,3] & [4].

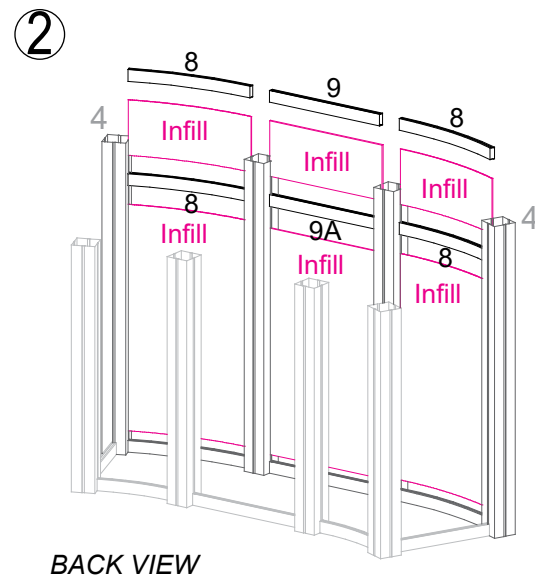

Insert lower & upper front infills between verticals [4], securing with horizontal extrusions [8,9,9A].

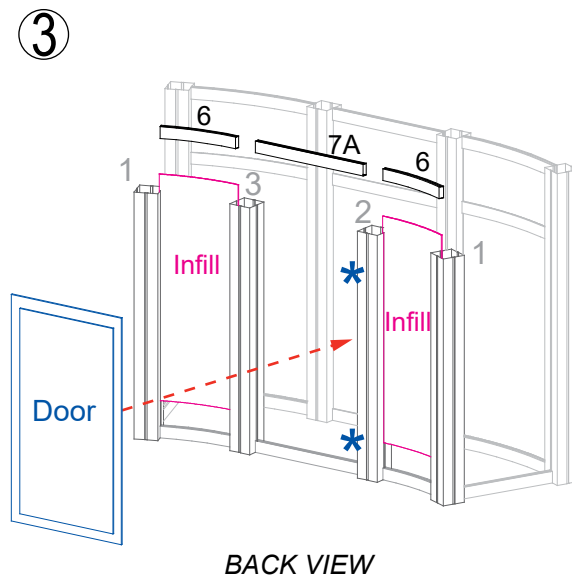

Install Door between verticals [2,3]. Then attach horizontal [7A] between verticals [2,3]. Slide back infills between verticals [1,2] & [3,4] & secure with upper horizontals [6].

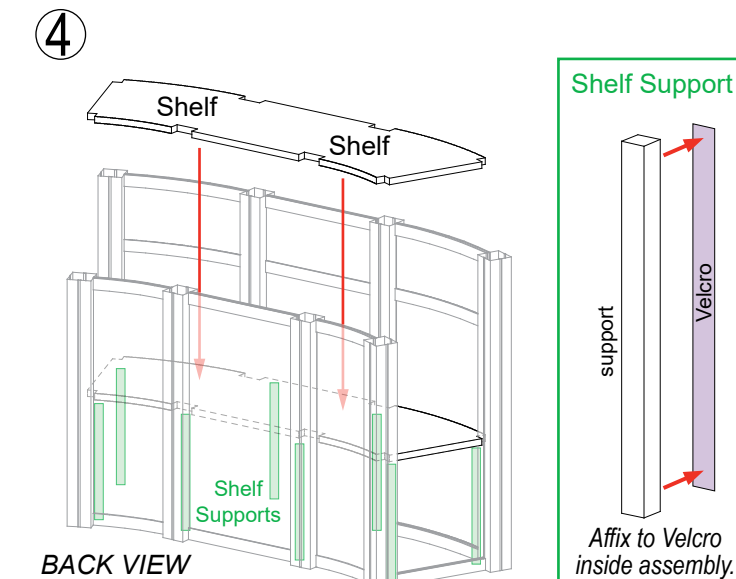
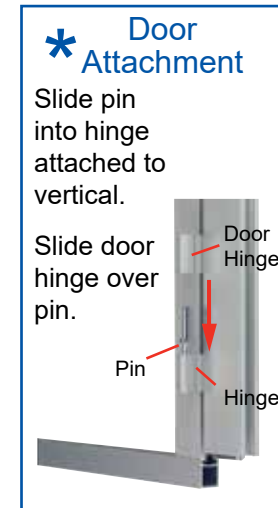

Affix Shelf Supports to Velcro on inside of counter; place internal Shelf onto shelf supports.

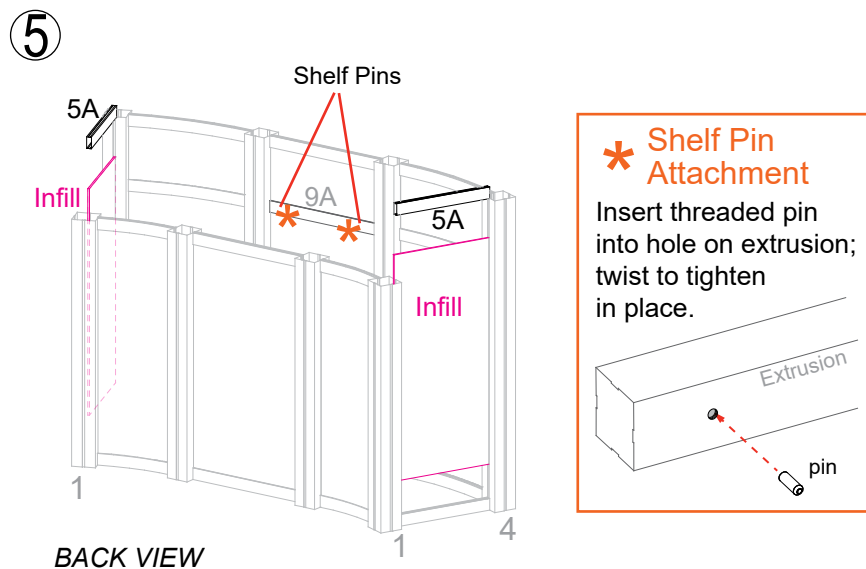

Insert side infills between verticals [1,4], then attach horizontal [5A] between verticals, securing infills. Attach Shelf Pins to horizontal [9A].

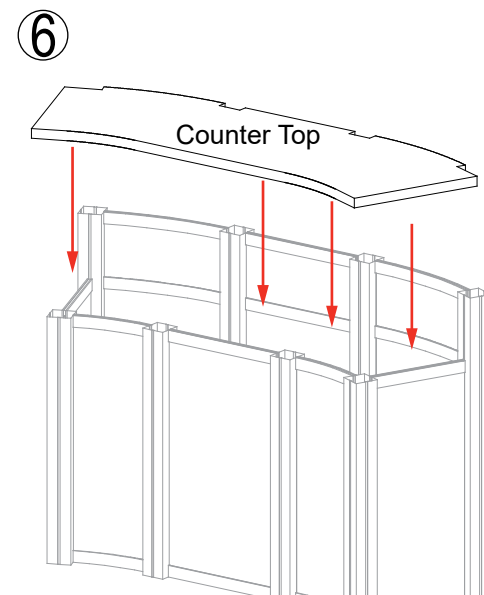
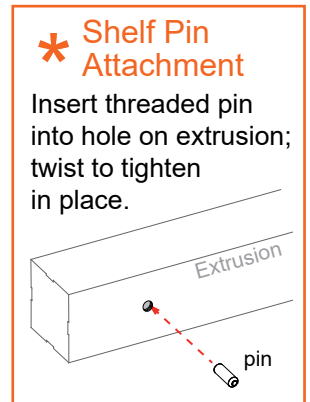

Place Lower Counter Top onto counter assembly.

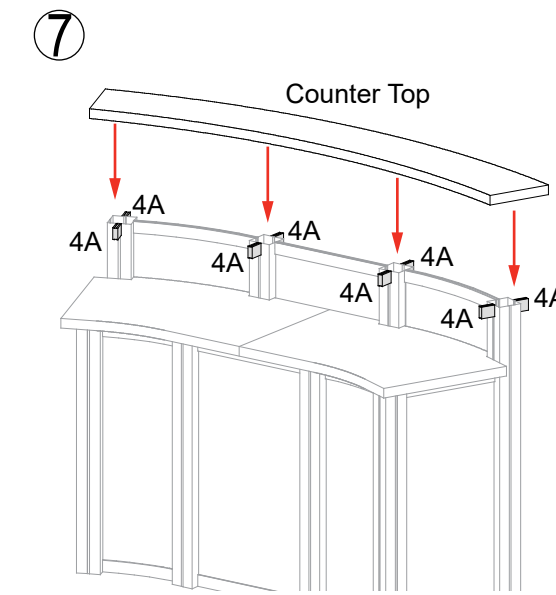
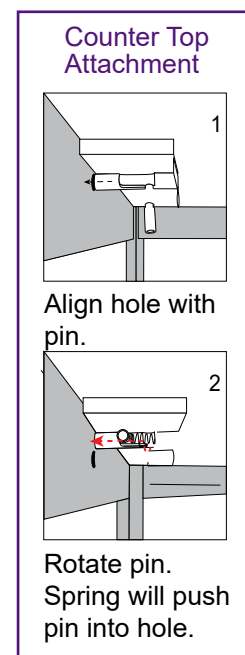

Attach support horizontals [4A] to front & back of verticals [4]. Place Upper Counter Top onto assembly.

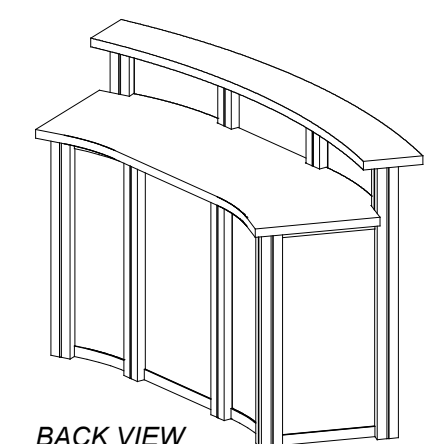
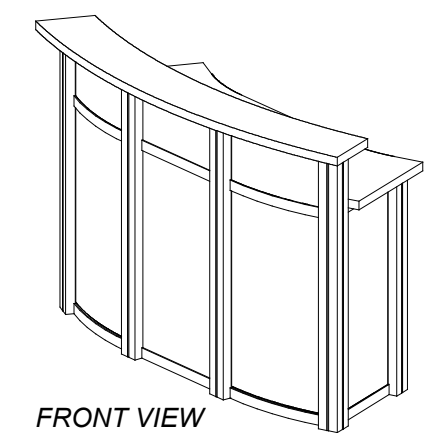
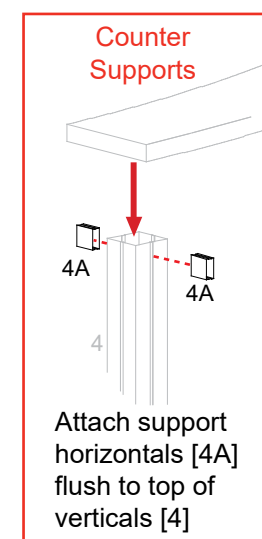

Completed Assembly

Item	Qty.	Description
1	2	38" h Q914 Vertical Extrusion
2,3	1,1	38" h Q914 Vertical Extrusion w/ Door Hardware
4	4	48" h Q914 Vertical Extrusion
4A	8	Horizontal Counter Supports
5/5A	2/2	16" w Z45 Horizontal Extrusion

Item	Qty.	Description
6	4	12.4563" Z45 curved Horizontal Extrusion
7/7A	1/1	19.573" w Z45 Horizontal Extrusion
8	6	20" w Z45 curved Horizontal Extrusion
9	2	20" w Z45 Horizontal Extrusion
9A	1	20" w Z45 Horizontal Extrusion w/ counter connection

# SETUP INSTRUCTIONS

## General Setup Instructions

- Read entire setup instruction manual prior to unpacking parts and pieces.
- The setup instructions are created specifically for this configuration.
- Setup instructions are laid out sequentially in steps, including exploded views with detailed explanation for assembly.

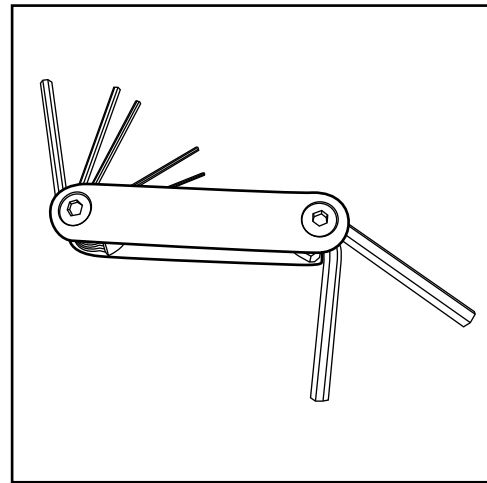

Hex Tool - Essential for Assembly

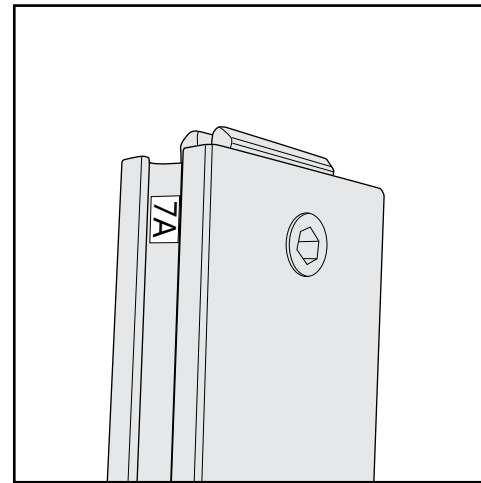

Part Identification - Numbering



# WARNING

## Cleaning & Packing

- For Cleaning Metal, Plex, & Laminate Parts: Use a **MILD NON-ABRASIVE** cleanser and soft cloth/paper towel to clean all surfaces.
- Keep exhibit components away from heat and prolonged sun exposure. **Heat and UV exposure will warp and fade components.**
- Retain all provided Packing Materials. All provided packing materials are for ease of repacking & component protection.

## Disassembly

- For loss prevention, tighten all set screws and locks during disassembly.

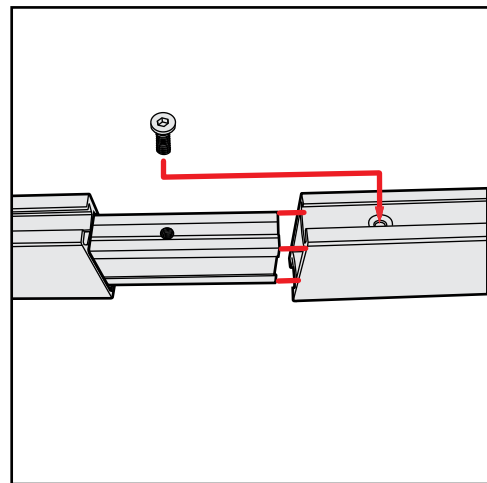

Spline Connection

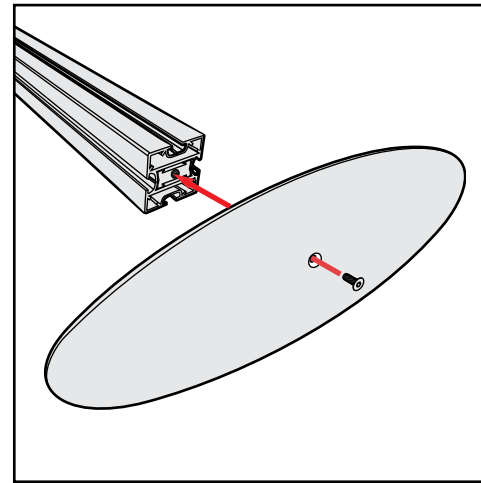

Base Plate & Extrusion Connection

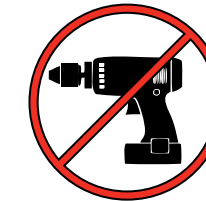

DO NOT USE POWER TOOLS

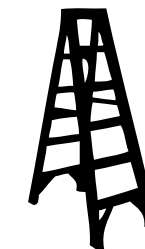

LADDERS OR LIFTS  
MAY BE REQUIRED

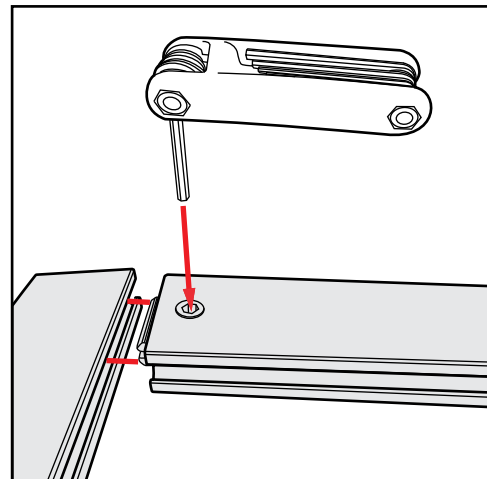

Extrusion & Lock Connection

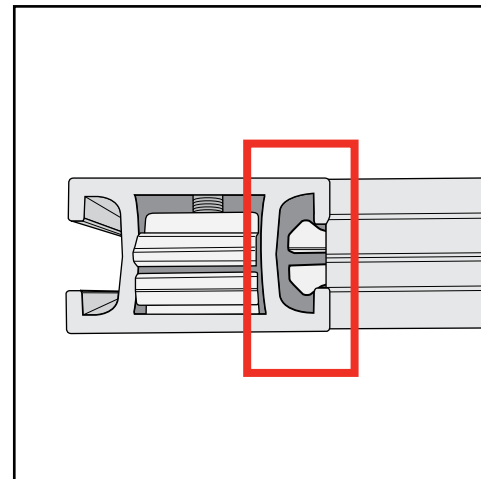

Engaged Lock



ALL CONNECTIONS MUST  
BE TIGHTLY SECURED